

APPLICATION

Refrigerant	R600a	Max. Ambient temp.	43 °C
Application	LBP	Max. Steady discharge temp.	120 °C
Expansion Device	Capillary	Max. Peak discharge temp.	135 °C
Cooling Type	Static	Max. Steady condensing temp.	60 °C
Evaporation temp. range	-35°C to -10°C	Max. Peak condensing temp.	70 °C
		Max. Winding temp.	130 °C

BASIC PARAMETER

Compressor Model	HKD86FSK(I)	Rated Voltage	200~240 V
Displacement	8.6 cc	Rated Frequency	50/60 Hz
Net Weight	8.0 kg	Motor type	PMSM
Oil Type	WF7A	Electrical insulation class	B
Oil Charge	200 cc	Height (H)	163 mm
Oil Viscosity @40°C	7 cSt		

ELECTRICAL DATA

Enamelled Wires Material	Cu
Line-line Resistance @20°C	9.2 Ω
Starting Device	Electronic Driver
Speed Range	1400~4000 rpm
Connecting board	ESD

PERFORMANCE DATA

Speed	Cooling Capacity	Input Power	COP	Current
rpm	W	W	W/W	A
1400	71	39	1.85	0.19
2400	119	61	1.95	0.31
4000	194	108	1.8	0.54

Evaporating temp.	-23.3 °C
Condensing temp.	+55 °C
Subcooling temp.	+32 °C
Suction temp.	+32 °C
Ambient temp.	+32 °C

COMPRESSOR OUTLINE

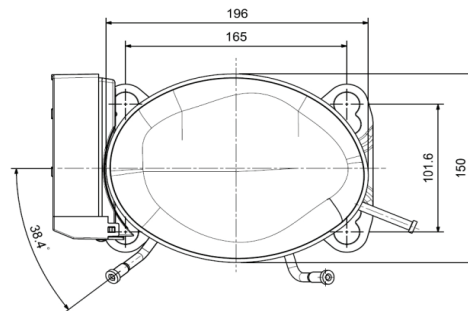
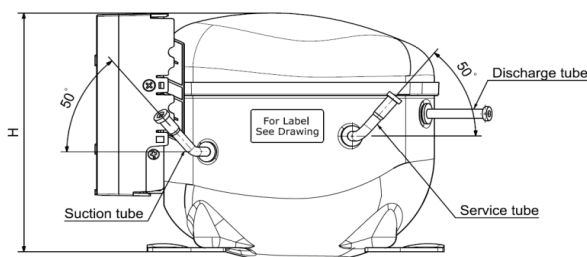

* H is shown in basic parameter.